



# 快速安装指导

## 储能逆变器

### EM系列

(GW5048-EM | GW3648-EM | GW3048-EM)

V1.1-2022-12-30

## 01 安全注意事项

### 通用声明

- 因产品版本升级或其他原因,文档内容会不定期进行更新,如无特殊约定,文档内容不可取代产品标签或用户手册中的安全注意事项。文档中的所有描述仅作为使用指导。
- 安装前,请认真阅读快速安装指导。如需更多信息,请参考用户手册。
- 设备所有操作必须由专业、合格的电气技术人员进行,技术人员需熟知项目所在地相关标准及安全规范。
- 安装设备前请检查交付件类型是否与订单相符、数量是否齐全、外观是否损坏。如有异常请联系售后服务中心。
- 逆变器进行操作时,需使用绝缘工具,佩戴个人防护用品,确保人身安全。接触电子器件需佩戴静电手套、静电手环、防静电服等,保护逆变器不受静电损坏。
- 未按照本文档或对应用户手册要求安装、使用、配置逆变器造成的设备损坏或人员伤害,不在设备厂商责任范围之内。更多产品质保信息请通过官网获取:<https://www.goodwe.com/warrantyrelated.html>

### 安全声明



#### 警告

#### 直流侧:









1. 确保组件边框和支架系统接地良好。
2. 请使用随箱配发的直流连接器连接逆变器直流线缆。如果使用其他型号的直流连接器,因此引起的设备损坏不在设备产商责任范围之内。
3. 确保直流线缆连接正确、紧固、无松动。接线不当可能导致接触不良或阻抗高,并损坏逆变器。
4. 使用万用表测量直流线缆,确保正负极正确,未出现反接;电压应低于最大直流输入电压。由于反接和过电压造成的损坏,不在设备产商责任范围之内。
5. 光伏组件的最小对地阻抗必须大于 $R(R=\text{最大输入电压}(V)/30\text{mA})$ ,否则会有电击危险。
6. 在连接电池与逆变器前,请确保电池开关已断开,且逆变器未连接光伏板和其他交流电源;电池额定电压需符合逆变器产品规格。
7. 与逆变器配套使用的光伏组件必须符合IEC61730 A级标准。

#### 交流侧:

1. 确保并网接入点的电压和频率符合逆变器并网规格。
2. 逆变器交流侧推荐增加断路器或保险丝等保护装置,保护装置规格应至少为逆变器交流输出最大电流的1.25倍。
3. 逆变器的保护地线必须连接牢固。
4. 交流输出线推荐使用铜芯线缆,如需使用铝线,请使用铜铝过渡端子进行接线。

#### 逆变器侧:

1. 逆变器安装过程中请避免底部接线端子承重,否则将导致端子损坏。
2. 逆变器安装后,箱体上的标签、警示标志必须清晰可见,禁止遮挡、涂改、损坏。
3. 逆变器运行时箱体温度可能超过 $60^{\circ}\text{C}$ ,冷却之前请勿触摸箱体;请勿安装在儿童可触碰范围内。
4. 未经授权擅自拆卸或改装可能造成设备损坏,此损坏不在质保范围内。
5. 若使用逆变器BACKUP功能,请正确连接BACKUP端子后进行并网;若未连接至电池,建议不要开启BACKUP功能。
6. 远离强磁场环境,避免电磁干扰。如果安装位置附近有无线电台或者30MHz以下无线通信设备,请按照以下要求安装设备:
  - 在逆变器直流输入线或交流输出线处增加多圈绕组的铁氧体磁芯,或增加低通EMI滤波器
  - 逆变器与无线电磁干扰设备之间的距离超过30m。
7. 逆变器箱体上的警示标签如下:

	高电压危险。逆变器运行时存在高压,对逆变器进行操作时,请确保逆变器已断电。		延时放电。设备下电后,请等待5分钟至设备完全放电。
	操作设备前,请仔细阅读产品说明书。		设备运行后存在潜在危险。操作时,请做好防护。
	逆变器表面存在高温,设备运行时禁止触摸,否则可能导致烫伤。		保护接地线连接点。
	CE 标志		设备不可当做生活垃圾处理,请根据当地的法律法规处理设备,或者寄回给设备厂商。

## 上电前检查

编号	检查项
1	逆变器安装牢固,安装位置便于操作维护,安装空间便于通风散热,安装环境干净整洁。
2	保护地线、直流输入线、交流输出线、通信线连接正确且牢固。
3	线缆绑扎符合走线要求、分布合理、无破损。
4	未使用的端口已封堵。
5	逆变器并网接入点的电压和频率符合并网要求。

## EU符合性声明

























可在欧洲市场销售的具有无线通信功能的设备满足以下指令要求:

- Radio Equipment Directive 2014/53/EU (RED)
  - Restrictions of Hazardous Substances Directive 2011/65/EU and (EU) 2015/863 (RoHS)
  - Waste Electrical and Electronic Equipment 2012/19/EU
  - Registration, Evaluation, Authorization and Restriction of Chemicals (EC) No 1907/2006 (REACH)
- 更多EU符合性声明,可从官网获取: <https://en.goodwe.com>。

可在欧洲市场销售的不具有无线通信功能的设备满足以下指令要求:

- Electromagnetic compatibility Directive 2014/30/EU (EMC)
  - Electrical Apparatus Low Voltage Directive 2014/35/EU (LVD)
  - Restrictions of Hazardous Substances Directive 2011/65/EU and (EU) 2015/863 (RoHS)
  - Waste Electrical and Electronic Equipment 2012/19/EU
  - Registration, Evaluation, Authorization and Restriction of Chemicals (EC) No 1907/2006 (REACH)
- 更多EU符合性声明,可从官网获取: <https://en.goodwe.com>。

## LED 指示灯

指示灯	状态	说明
SYSTEM		常亮 = 系统已就绪
		单次闪烁 = 系统正在启动
		灭 = 系统未工作.
BACKUP		常亮 = BACKUP功能已就绪
		灭 = BACKUP功能已关闭
COM		常亮 = BMS和电表通讯正常k.
		单次闪烁 = 电表通讯正常, BMS断开
		两次闪烁 = BMS正常, 电表通讯断开
		灭 = BMS及电表连接均断开
BATTERY		常亮 = 电池充电中
		单次闪烁 = 电池放电中
		两次闪烁 = 电池电量低 / SOC低
		灭 = 电池已断开 / 未能正常工作
GRID		常亮 = 电网已连接, 正常工作
		闪烁 = 电网正常, 但未能并网
		灭 = 电网未能正常工作
ENERGY		常亮 = 从电网买电 / 买电
		单次闪烁 = 向电网供电 / 不买不卖
		两次闪烁 = 向电网供电 / 卖电.
		灭 = 未并网, 或系统未工作.
WiFi		常亮 = WiFi正常, 已连接
		单次闪烁 = WiFi正在重置
		两次闪烁 = WiFi未连接至路由器
		四次闪烁 = WiFi服务器问题
		灭 = WiFi未能正常工作
FAULT		常亮 = 故障
		单次闪烁 = BACKUP过载/减轻负载
		灭 = 无故障

## 02 产品简介

### 部件

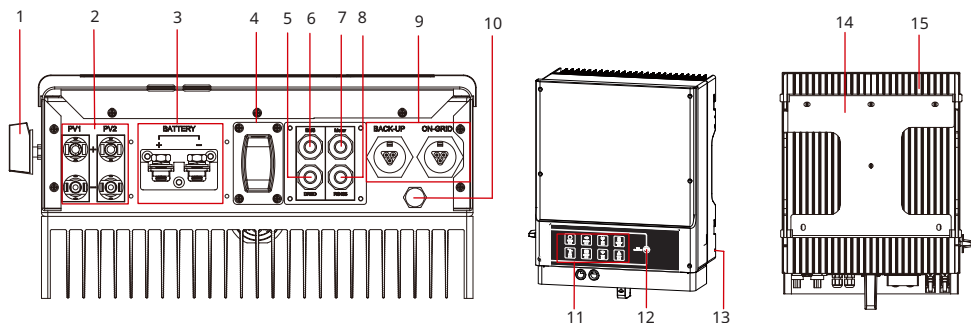

1. 直流开关(可选)
2. 光伏直流输入端口 (PV1/PV2)
3. 储能直流输入端口 (BATTERY +/-)
4. 通讯模块接口 (WiFi)
5. 通讯端口 (DRED或远程关断)
6. BMS通讯端口
7. METER通讯端口
8. RS485通讯端口
9. 交流输出端口(并网和 backup)
10. 排气阀
11. 指示灯
12. WiFi重置按钮
13. 保护接地端子
14. 挂装件
15. 散热片

### 尺寸

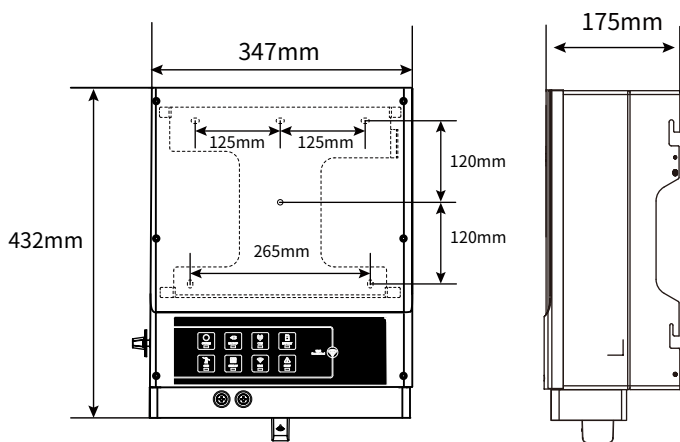

### 03 安装逆变器

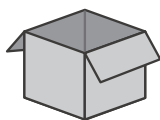
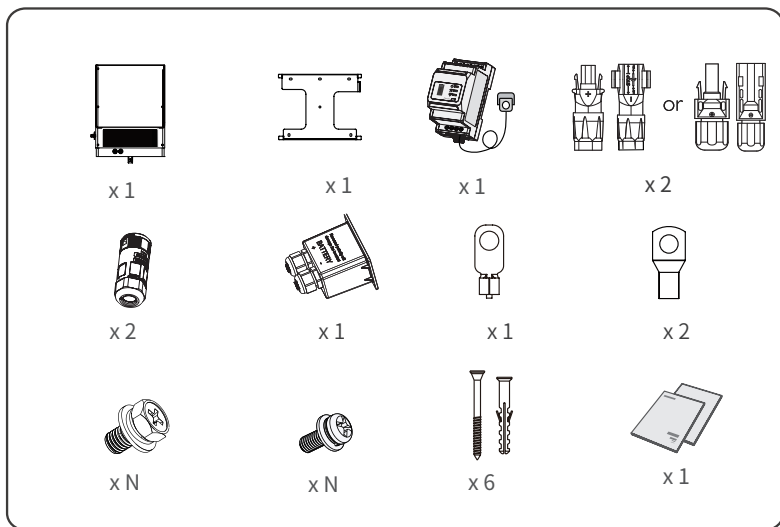

N:表示该附件数量依据产品配置而定。

#### 位置要求

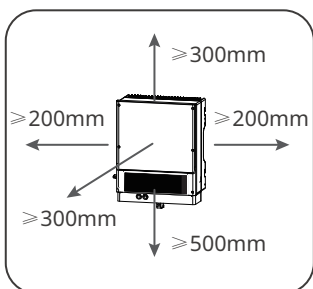
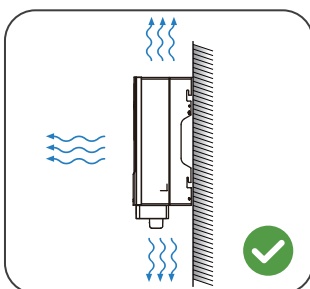
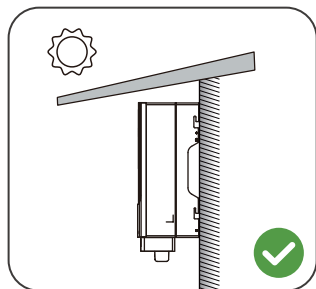
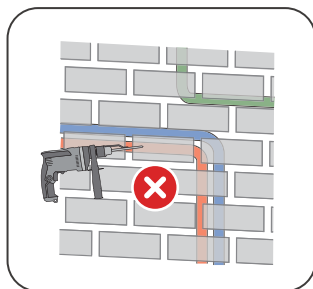

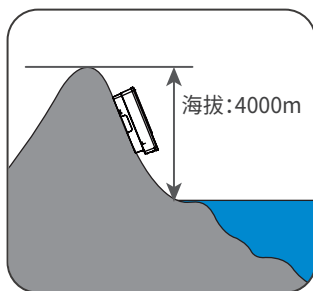
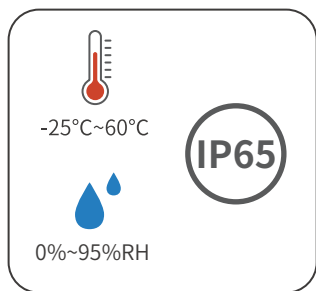

### 角度要求

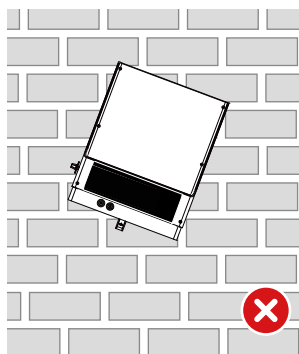
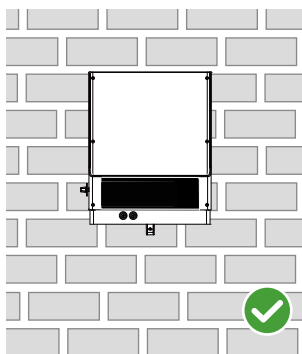
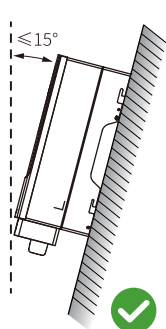

### 安装逆变器

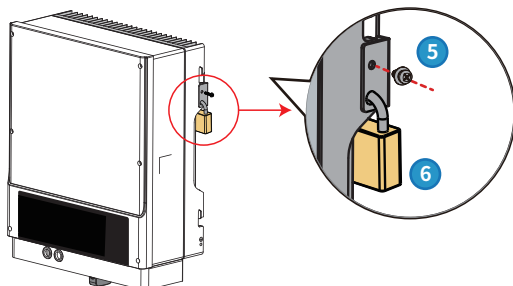
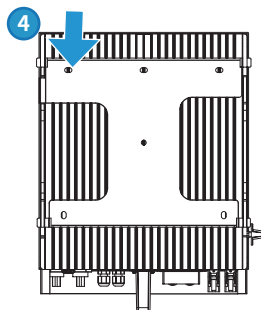
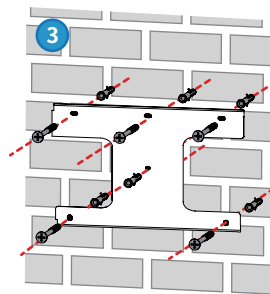
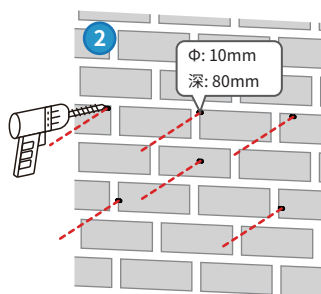
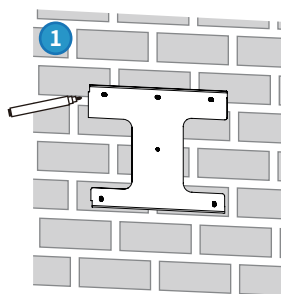

## 04 电气连接

### 连接保护地线

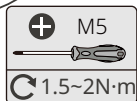
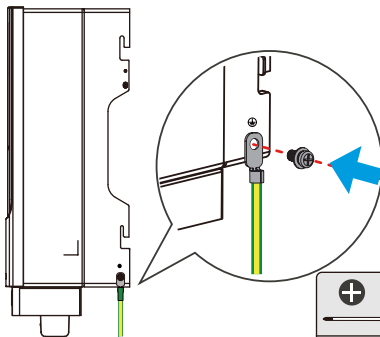
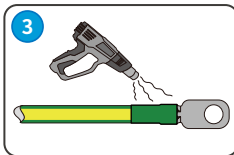
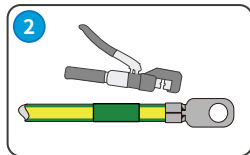
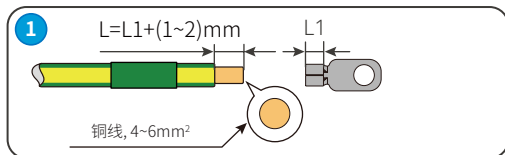

### 连接交流线

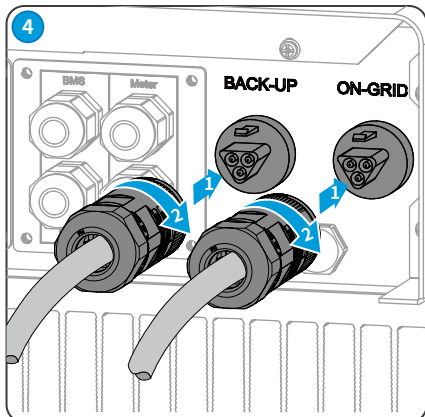
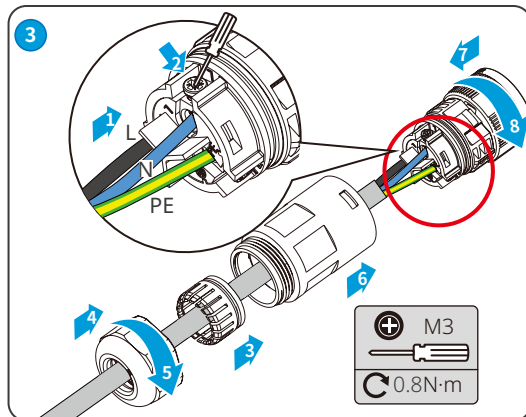
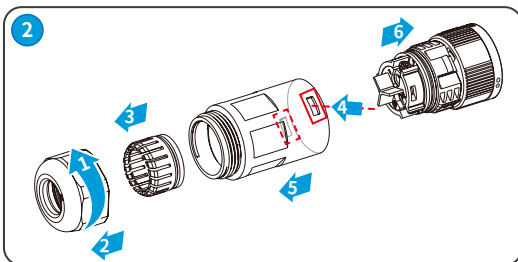
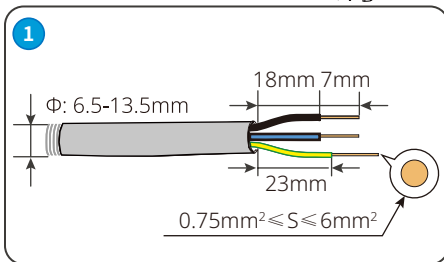
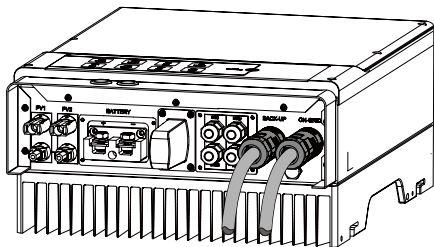



## 连接直流线

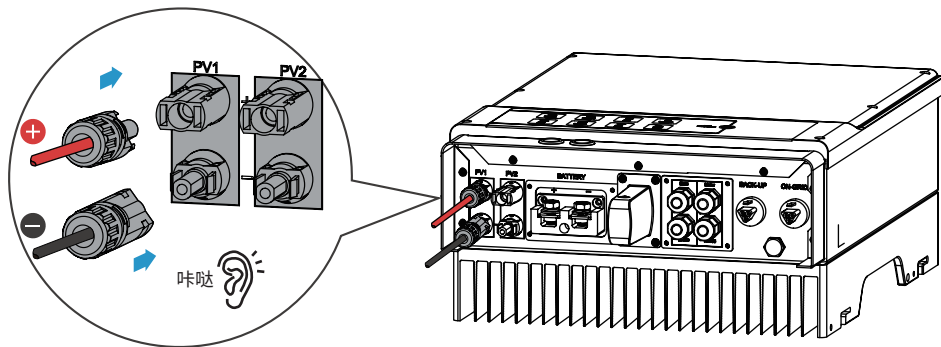

## MC4

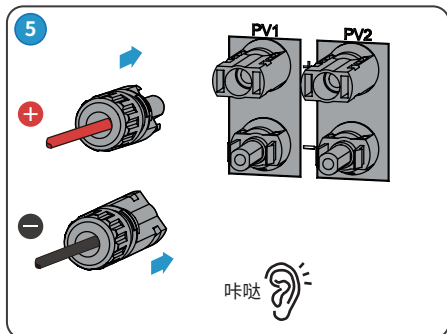
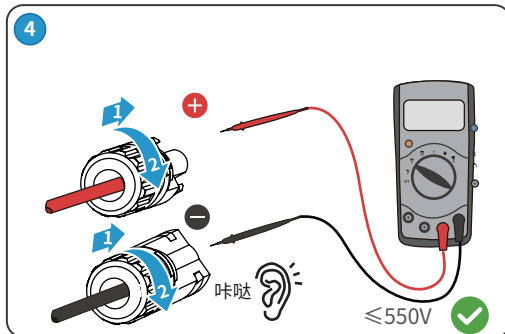
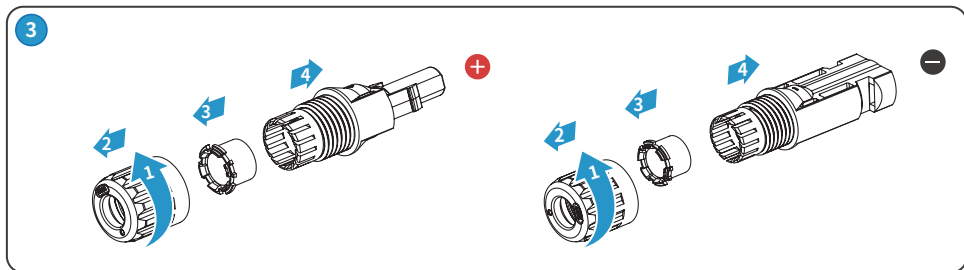
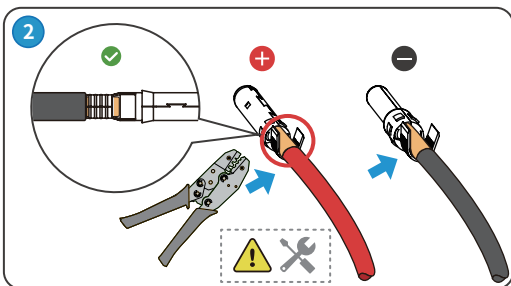
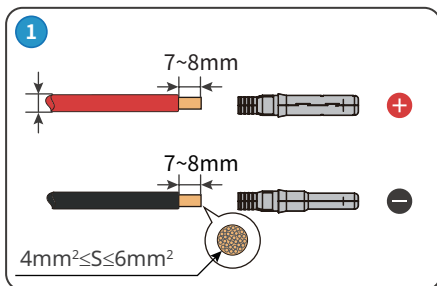

# 连接电池线

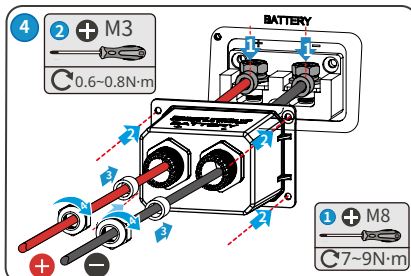
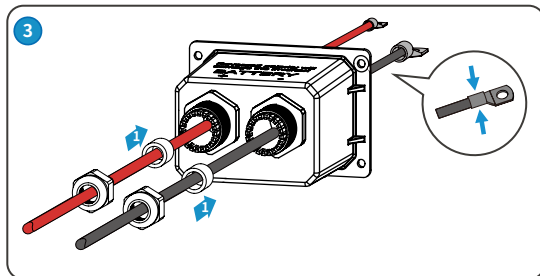
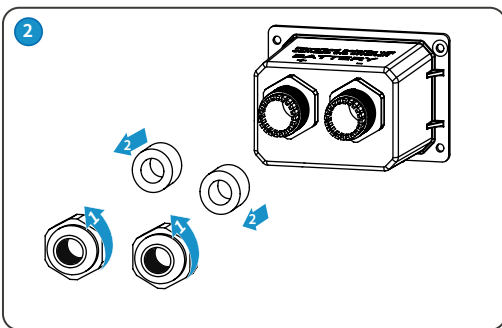
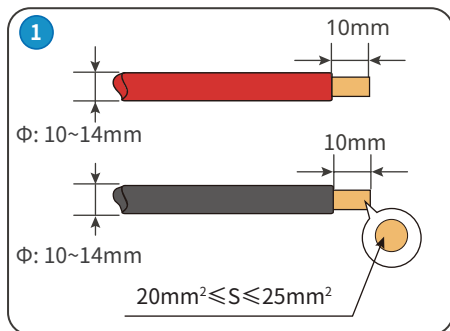
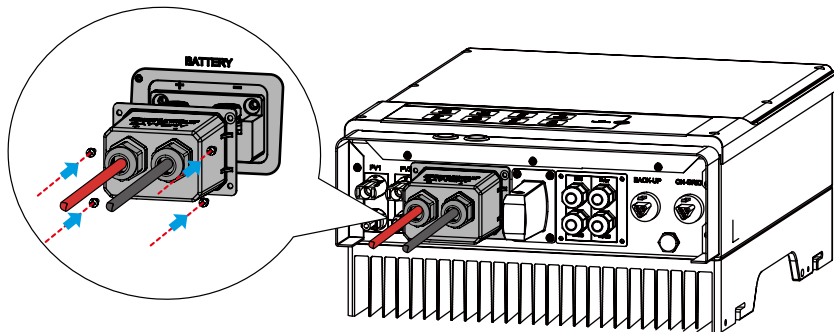

## 05 通信连接

### 连接DRED通讯线

- 注: DRED仅适用于澳洲和新西兰。

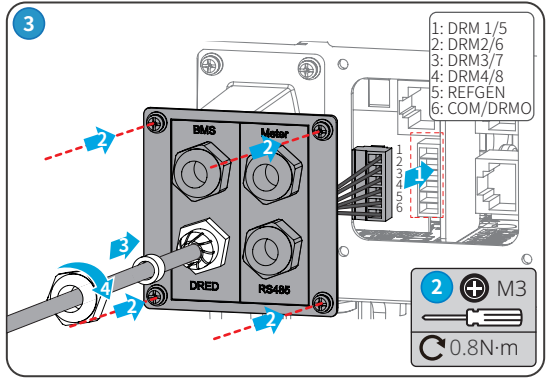
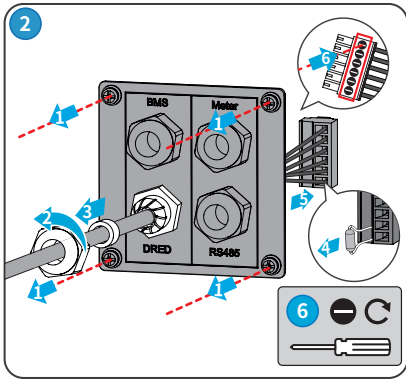
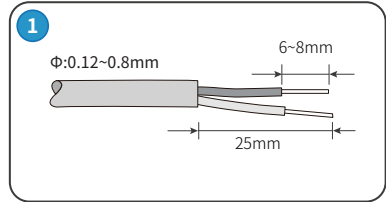
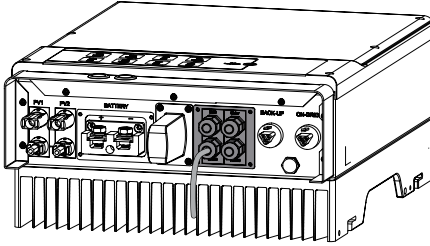

### 连接远程关断通讯线

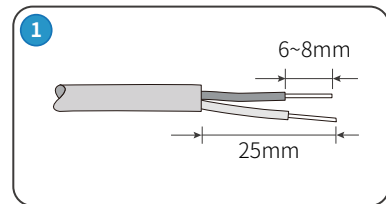
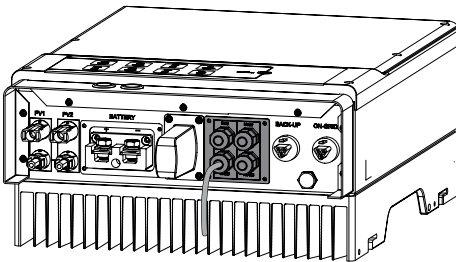

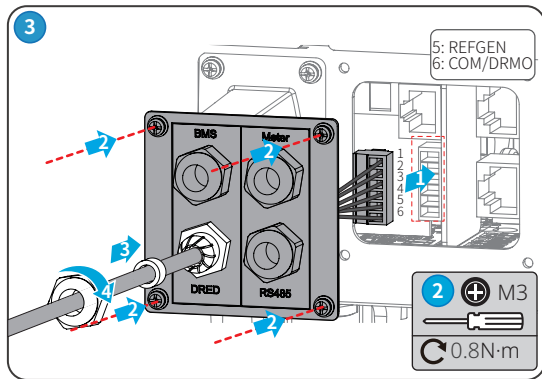
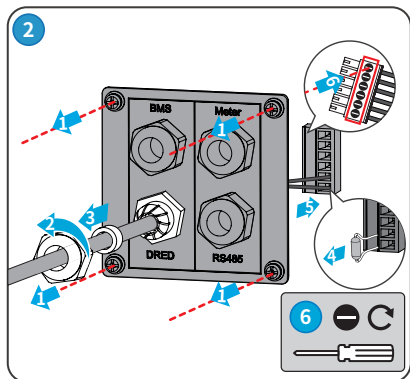

### 连接智能电表/电池

序号	颜色	BMS	智能电表
1	橙白	485_A2	NC
2	橙色	NC	NC
3	绿白	485_B2	485_B1
4	蓝色	CAN_H	NC
5	蓝白	CAN_L	NC
6	绿色	NC	485_A1
7	棕白	NC	485_B1
8	棕色	NC	485_A1

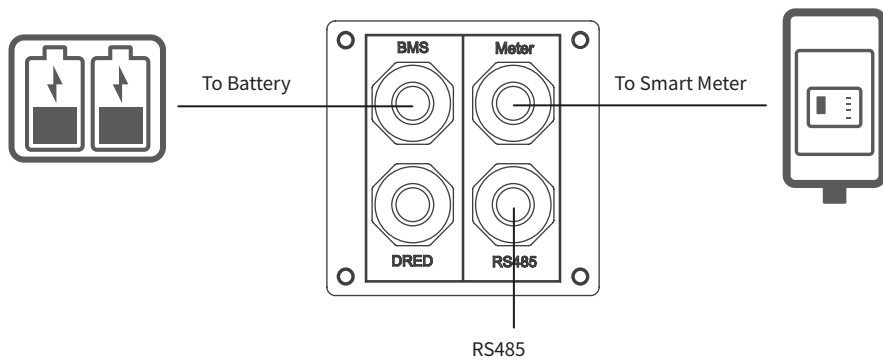
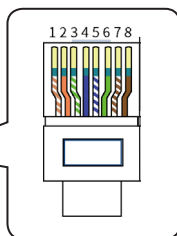

## 推荐断路器规格

型号	①	② ③	④ ⑤
GW3048-EM	63A/60V 直流断路器	32A/230V 交流断路器	取决于负载
GW3648-EM		32A/230V 交流断路器	
GW5048-EM		32A/230V 交流断路器	

## 上电步骤

闭合：⑤ → ③ → ① → ⑥ → ④ → ②

## 下电步骤

断开：③ → ⑤ → ④ → ② → ① → ⑥

若逆变器未配置内置直流开关, 请使用外置直流断路器。

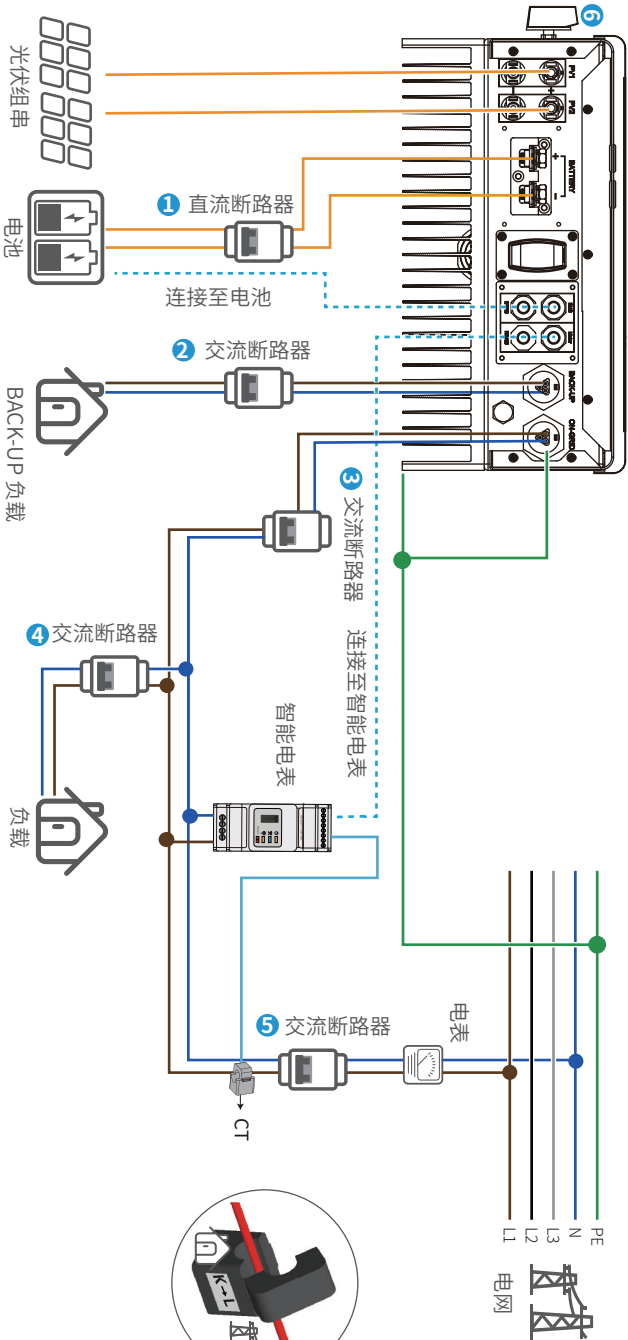

### 通过SolarGo App调测设备

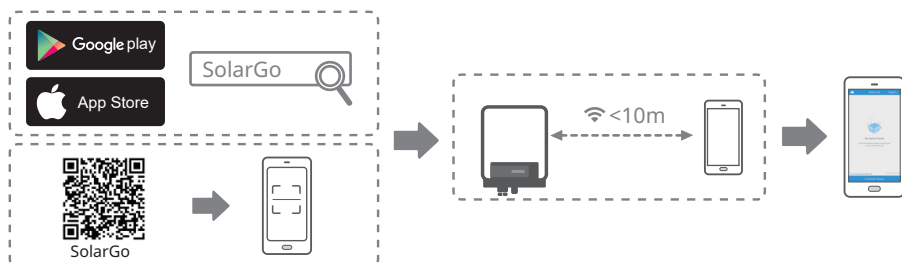

### 通过小固云窗监控设备

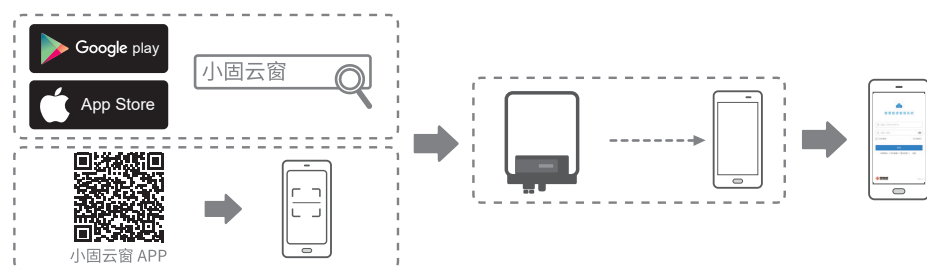

更多详细说明, 请扫描下方二维码获取。



WiFi配置手册





SolarGo App  
用户手册



固德威官网

固德威技术股份有限公司

 中国 苏州 高新区紫金路90号

 400-998-1212

 [www.goodwe.com](http://www.goodwe.com)

 [service@goodwe.com](mailto:service@goodwe.com)



340-00758-00

联系我们